

MORE LUXURY...  
MORE PROJECTS...





AEROLUX



Innovative, modern and functional outdoor patio solution...

Aerolux is an innovated bioclimatic pergola system with full-automatic tilting / retractable aluminum louvres and provides excellent protection from the sun, rain all the while providing beneficial ventilation.

Aerolux bioclimatic pergola system is a modern choice that adds value to outdoor living areas, it brightens the look of home, restaurant, hotel or cafes with a touch of luxury. The system is designed to be adapted any kind of outdoor living areas and provides exceptional quality of life in the open air with a high degree of visual and thermal comfort.

The louvres in dimensions 180x40 mm are made from a special aluminum alloy which ensures exceptional strength. They form a flat and smooth ceiling and drain the rainwater to the discrete gutter in fully closed position.

The construction of the system with 160x160 mm post allows a high degree of resistance to strong winds and wide span between support columns. Possibility of installation as self standing makes this pergola a sustainable solution for terraces, patios, balconies, pool houses, hot tubs and outdoor kitchens. Several modules can be linked to each other and even larger patio roof can be created by coupling multiple modules lengthwise.



■ Led Stripe Dimmer Lighting

■ RGB Led-Hidden Stripe Lighting



**Led Stripe Dimmer Lighting** illuminates all around the system and creates a warm atmosphere. Dimmable Soft Led Stripe lighting on sides within the structure provides intensity of day light or cool white options.

**RGB Led-Hidden Stripe Lighting** provides ultimate luxury by creating distinctive atmosphere in outdoor living areas with infinite colour options.



### Retractable & Tilting Version

Fully Closed



Retracted



Retracted & Tilted



### Tilting Version

Fully Closed



Tilted



Louvre Closing Direction

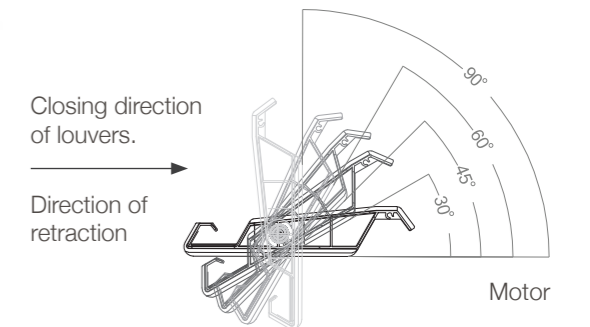

Tilting Directions





Flexible installation methods are available with wall mounting and free standing installations and they can even be served as a roof assembled to existing frameworks.



Self Standing  
Single Module



Wall Mounting  
Single Module



Self Standing  
Multiple Modules



Wall Mounting  
Multiple Modules



Blocked assembly for customized modules with a wide range of flexible combinations.

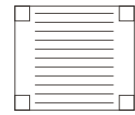

(w) Width  
1800 mm < 4000 mm

(p) Projection  
1569 mm < 6054 mm

(h) Height  
3000 mm

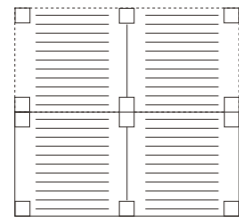
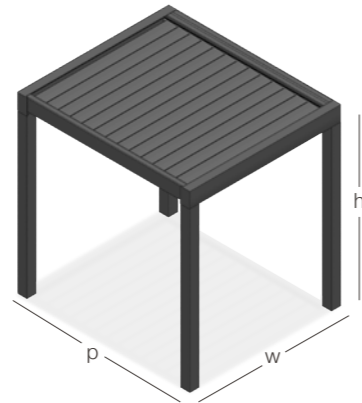

(w) Width  
3600 mm < 8000 mm

(p) Projection  
3138 mm < 12108 mm

(h) Height  
3000 mm

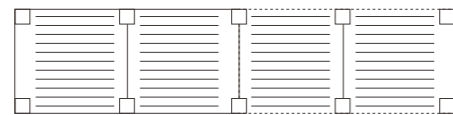
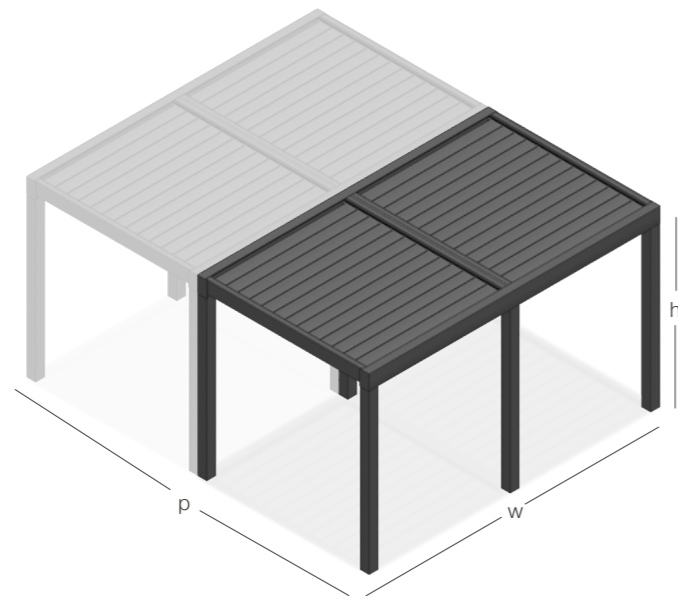

(w) Width  
7200 mm < 16000 mm

(p) Projection  
1569 mm < 6054 mm

(h) Height  
3000 mm

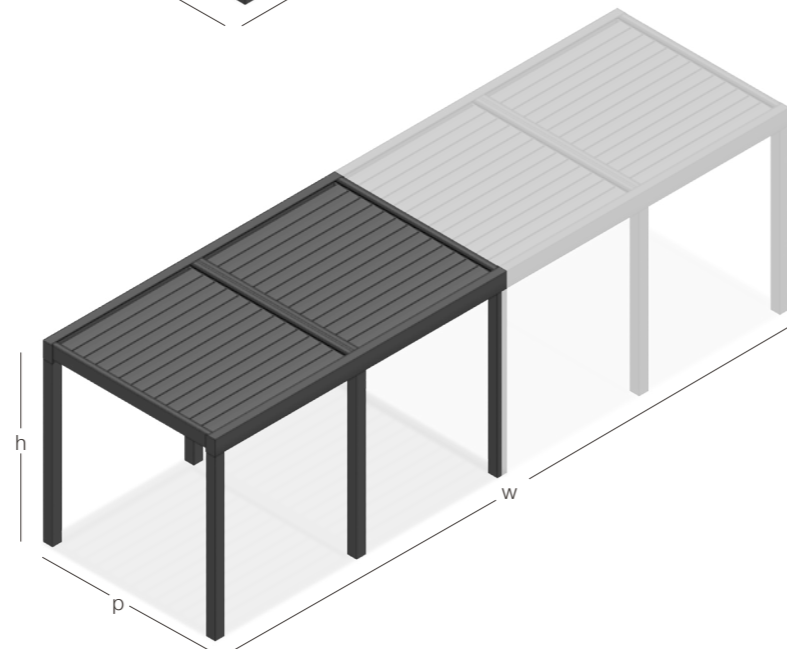

## Intra-Column Drainage Pipe

The water can be drained through internal drainage pipe and it eliminates factors that could block correct water flow. Intra-column drainage pipe collects the water and discharges to the ground.



### Column Base Options

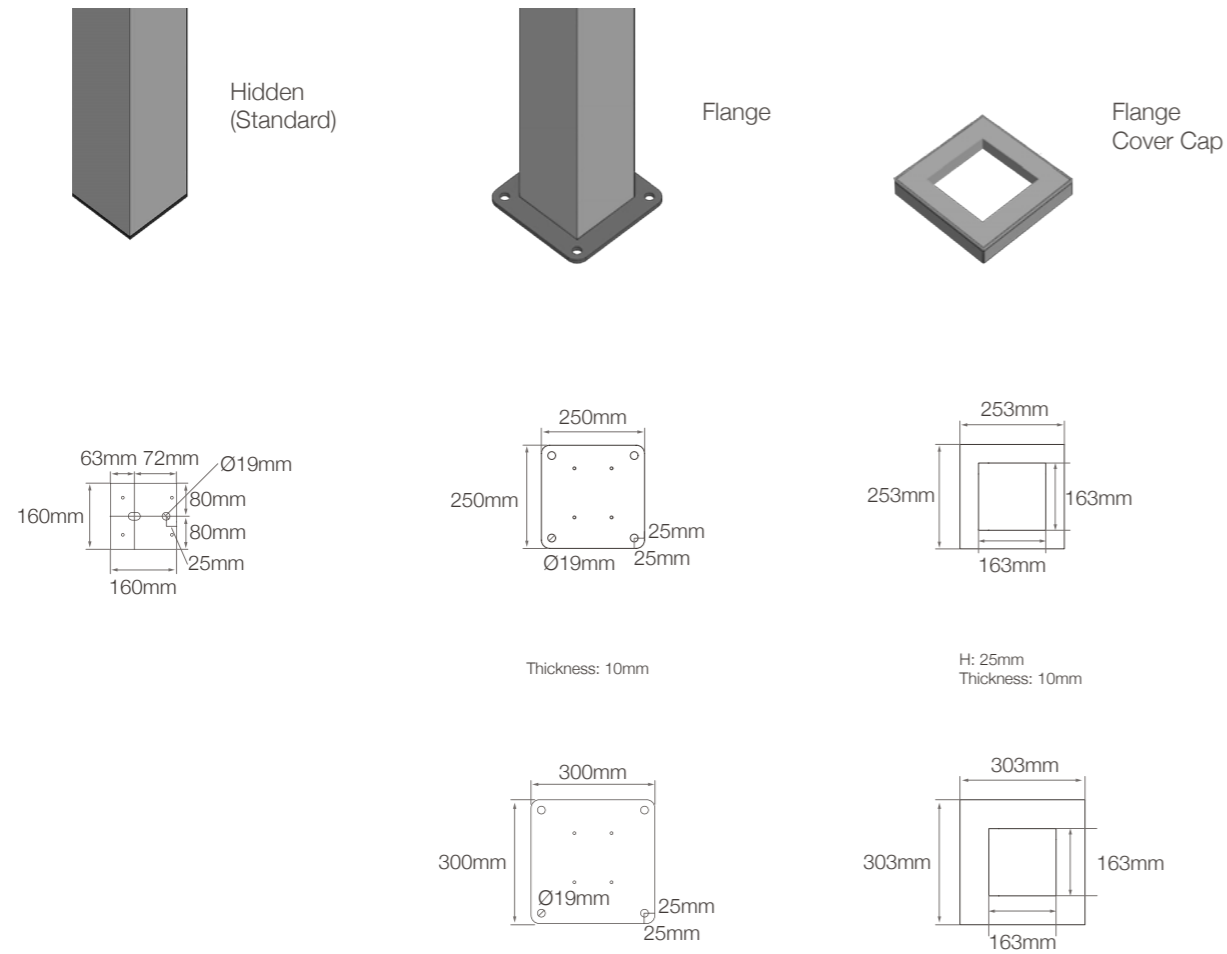

### Flange Positions

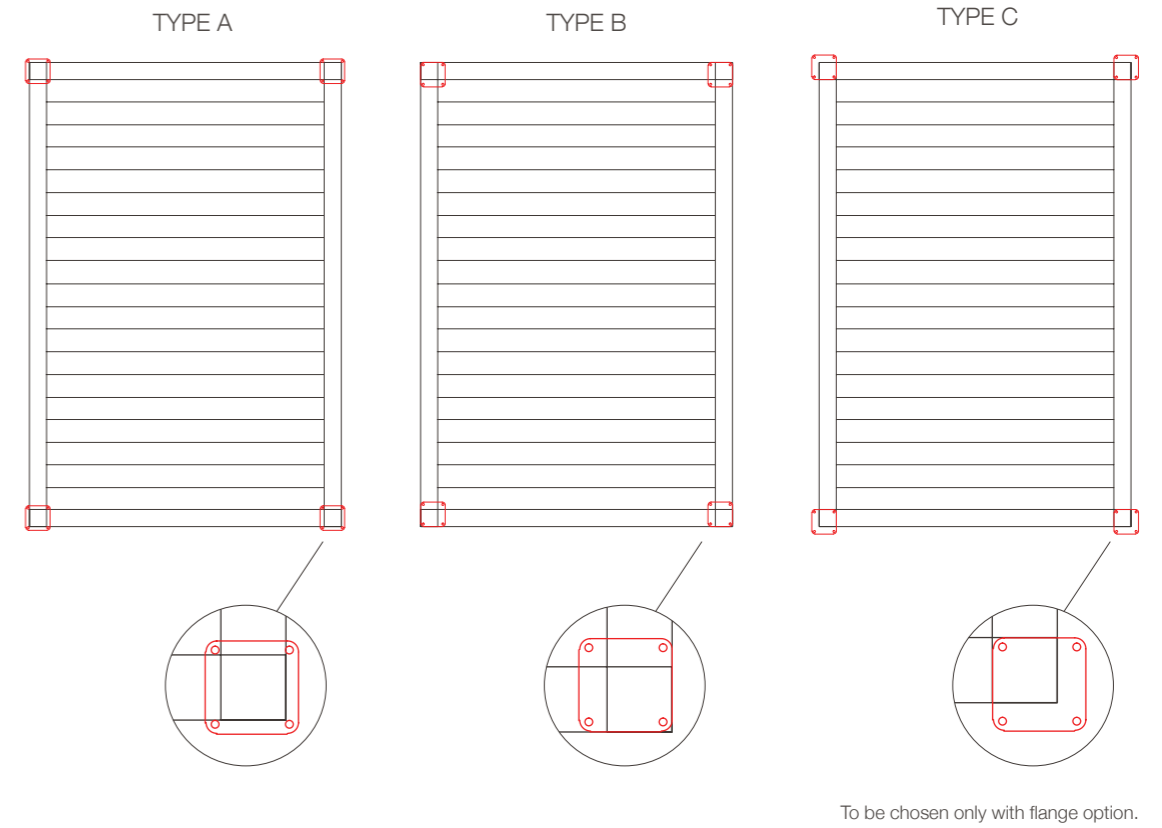

### Drainage Types

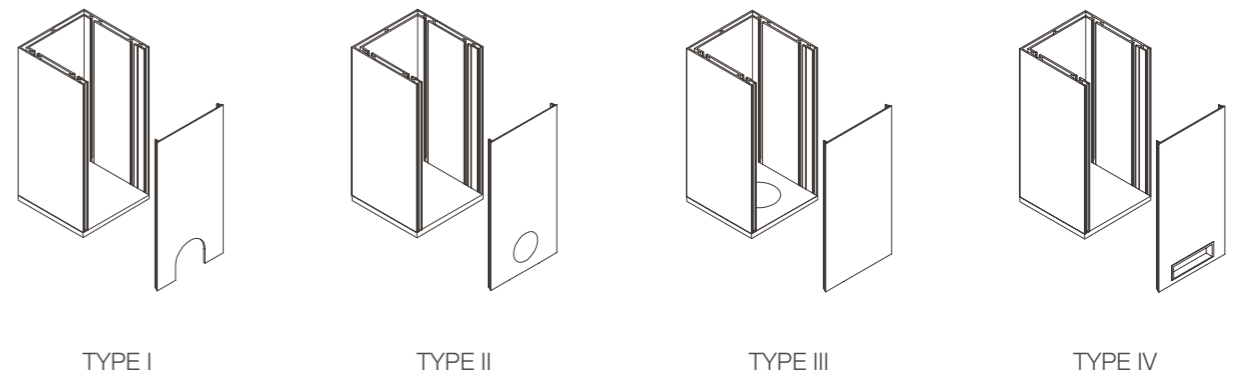



# Wall Installation Louvre Positions

Parallel To Wall

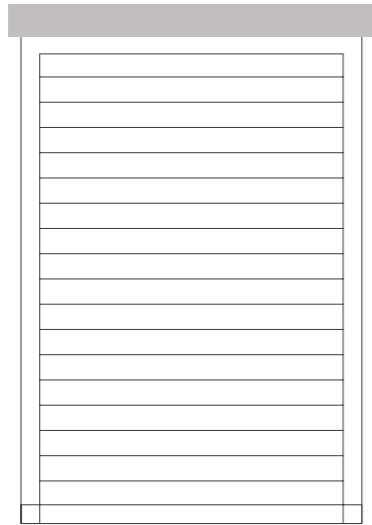

Vertical To Wall

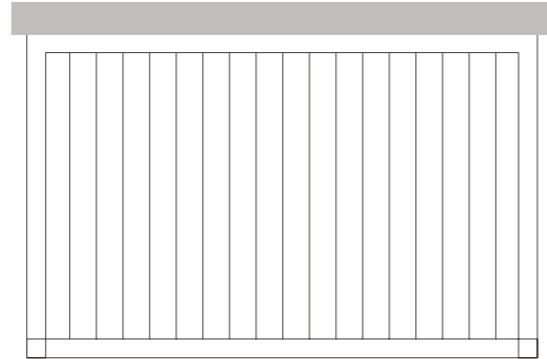

Inner (Hidden) Wall Bracket (Inox)

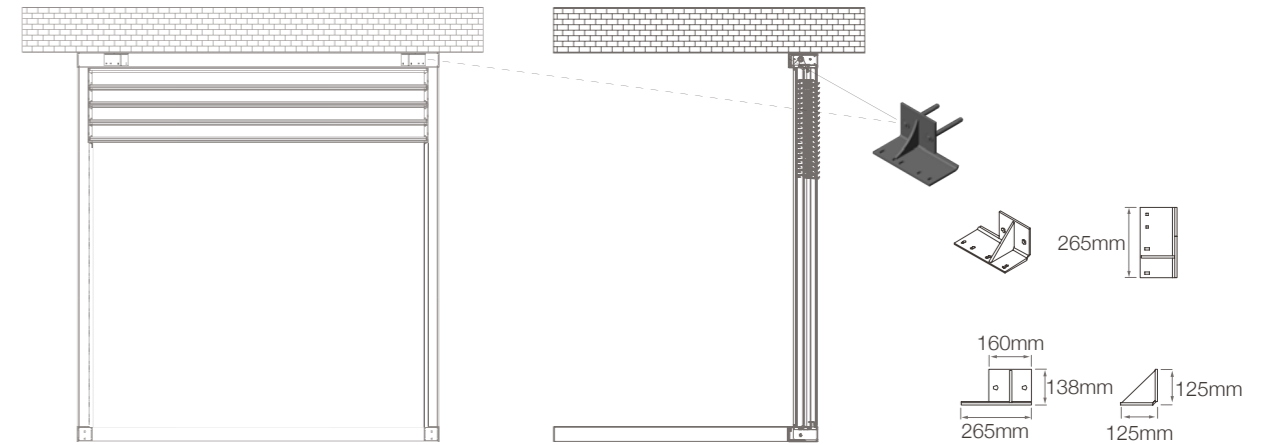

# Hang Bracket Types

Vertical Mounting Outer Wall Bracket (Inox) With Optional Cover Cap

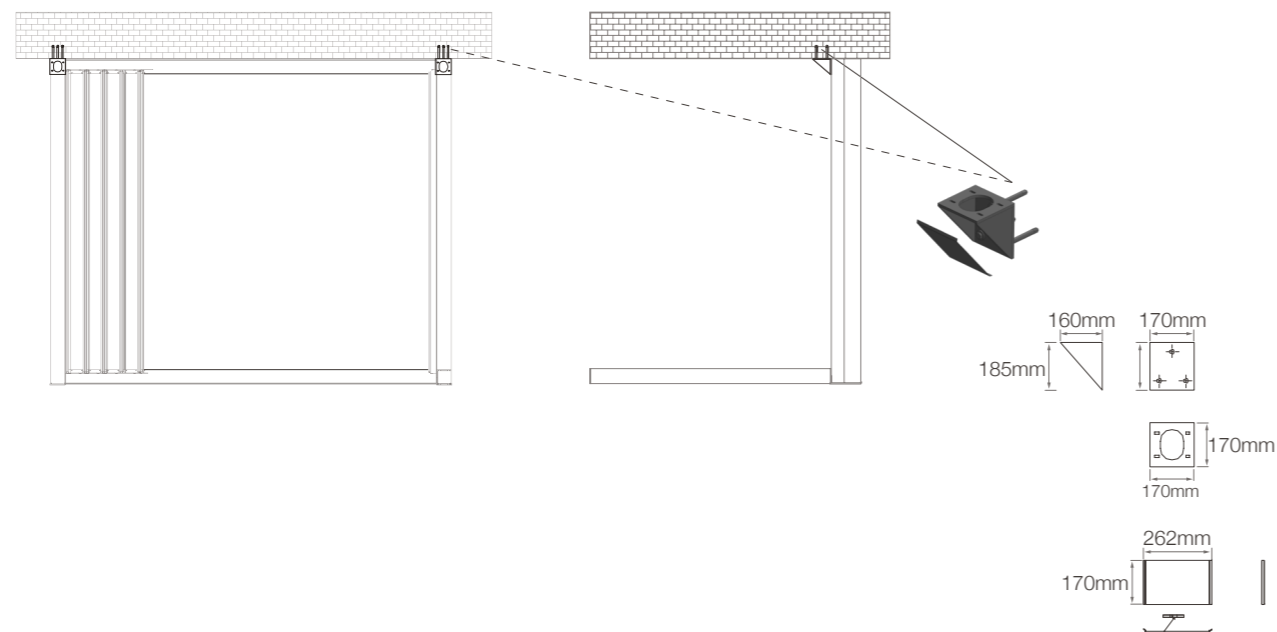

Parallel Mounting Outer Wall Bracket (Inox) With Optional Cap

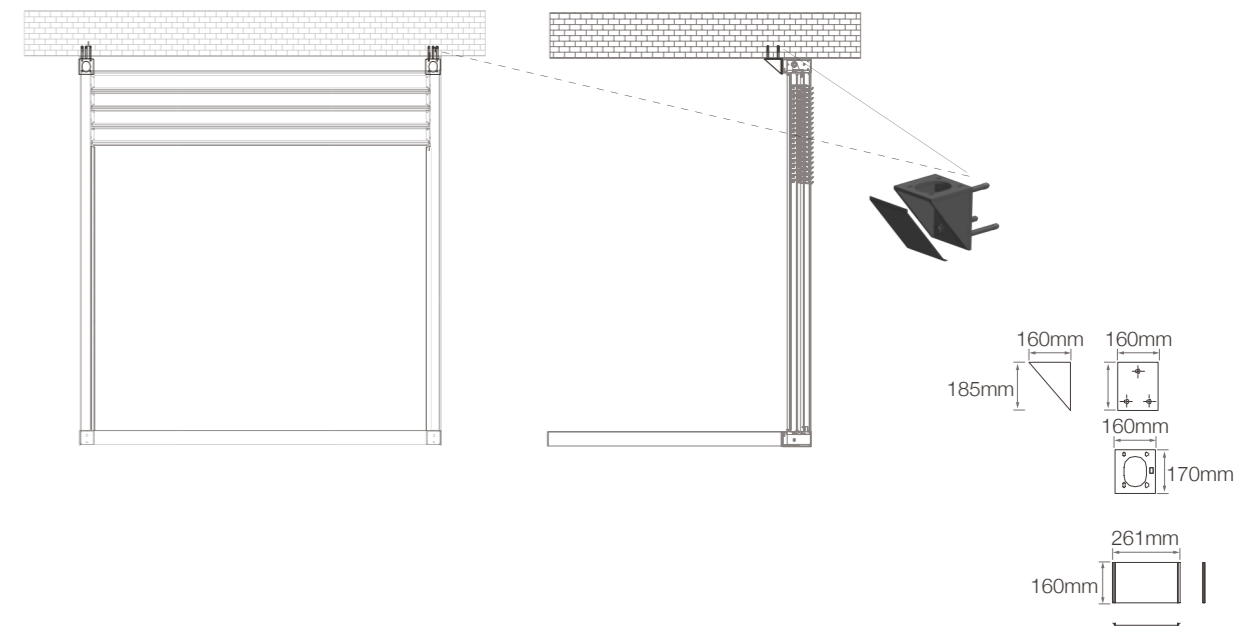



### Side Elevation

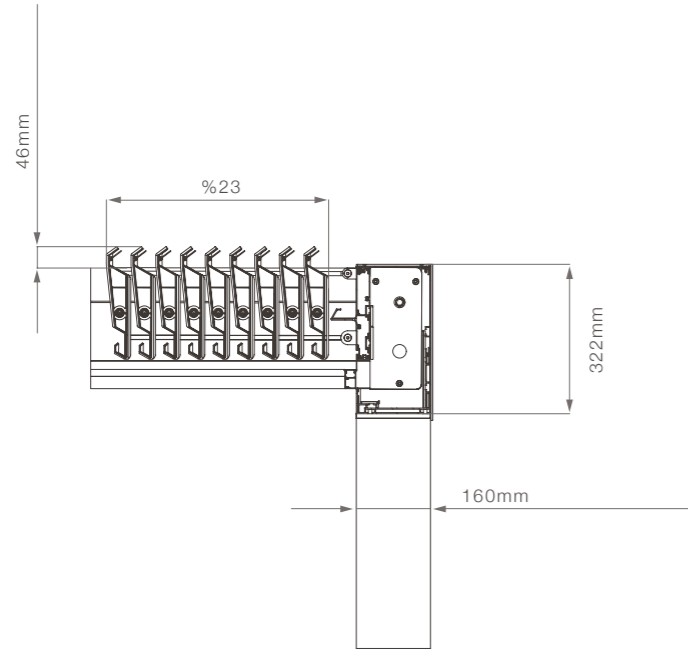

### Column Connection

Thanks to ease of column base assembly each columns can be installed practically through a series of simple operations that guarantee installation quality and speed to reduce number of staff required.

The front column cap can be pulled out simply and inner column cavity conceals the wiring cables of heater, speaker or automation to provide clean appearance.

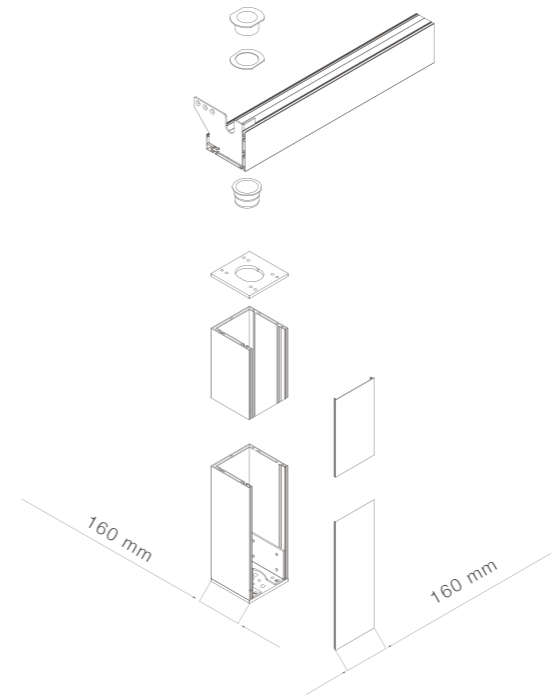

### Louvre Stormguard Seal

Sealing solution stops water dripping over louvre gutter channel by providing a soft cushioning barrier between point of louvre junction.

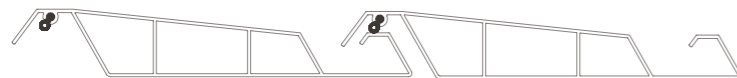



Slightly opening of louvres creates natural air flow for application areas.

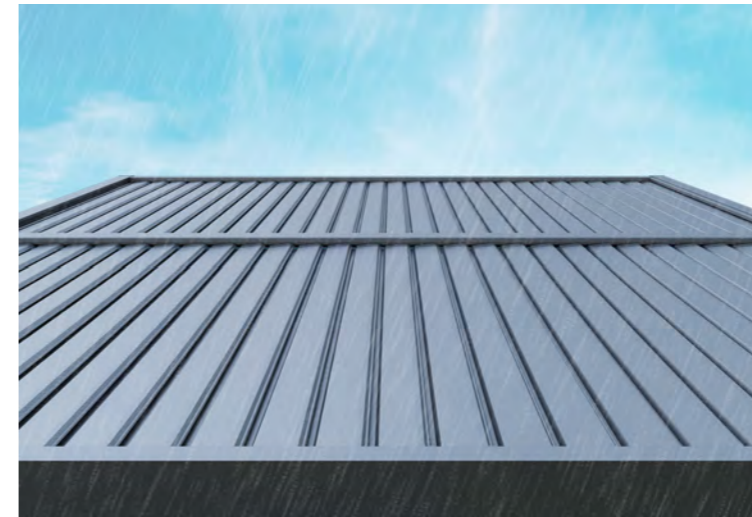

Ensuring waterproof coverage when louvres are in fully closed position.

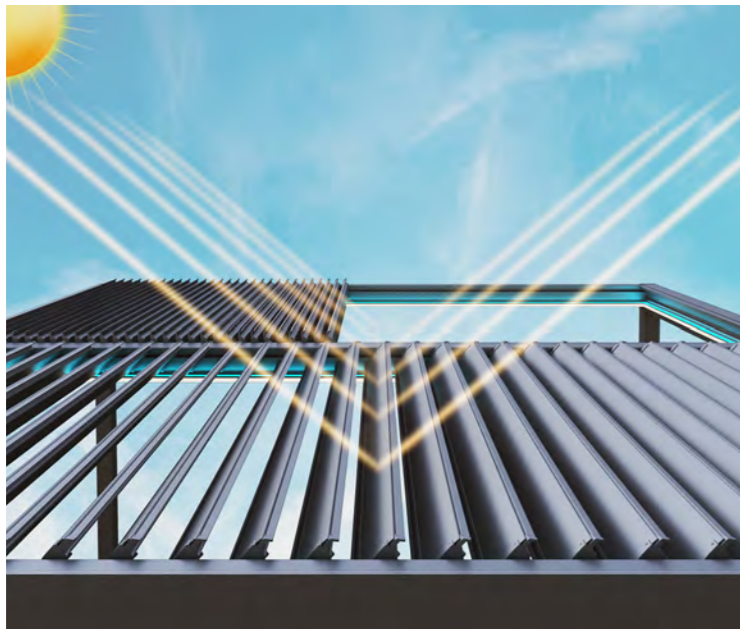

Protecting from sun exposure while ensuring air ventilation under the system .

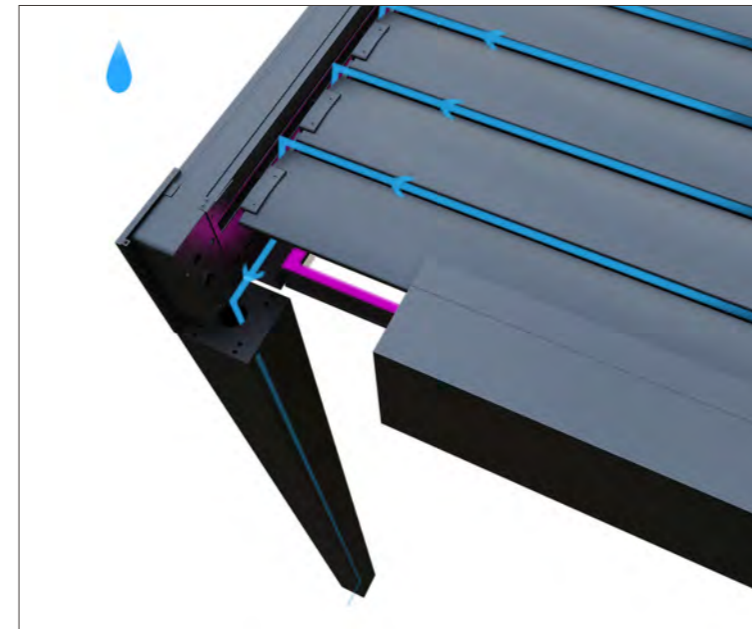

Each channel on louvres drain the water through four sided gutters connected with columns.



Functional seal entegrated on louvre channels provides maximum protection from water dripping.



Closures



**Sapphire/Cycle Guillotine Glass System**  
System can be adapted to Aerolux system and offers a maximum clear span that provides unobstructed view & minimalistic style. The system is operated by just the touch of button.



**Framee Sliding Glass System**  
Minimal line of Framee system is perfectly matching with modern architectural Aerolux system by insulated fine-framed sliding glass panels. System offers a comfortable sliding with easy individual movement.



**Swind-Motorised Windbreaker System**  
Swind can be combined with also Aerolux system and offers adequate wind breaking with the option of total transparency by incorporating the function of balustrade. Thanks to led stripe dimmer lighting integrated side frame the fixed panel assigns distinctive appeal. The system is modular and completely flexible as there are no limits in the horizontal direction that can be used to surround spaces of all types and sizes.

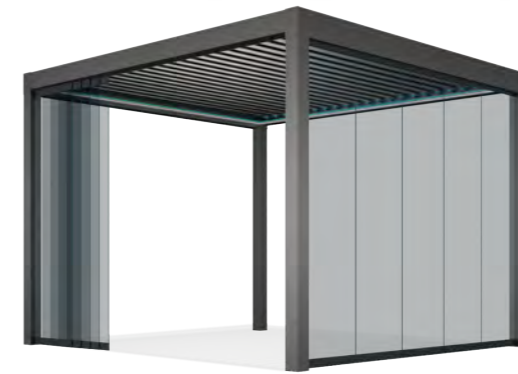

**Slidia Sliding Glass System**  
The combination of the sliding glass system with Aerolux ensures efficacious protection from wind and rain. The aluminium frames which cover each glass panel provide maximum safety standards and practicality with elegance details.



**Violet Glass Balustrade System**  
The adaptability of Violet fixed balustrade glass with Aerolux creates a stunning visual transparency without lacking of obstruction to lines of sight. The stylish lighting solution that is integrated underneath the glass highlights attractive aspect of the design by amplifying overall aesthetic of outdoors. Thanks to flexible and multiple modular implementations, system can be used to cover comprehensive areas without limitation in the horizontal direction.



**Vertex Zip Screen System**  
The minimalist, slimlane, contemporary design of the zip system provides comfortable shade and protects against the UV rays. The system includes motorised aluminium structure, entirely powder-coated with stainless steel bolts and screws.



**Wallfix Fixed Side Enclosure**  
The unique designed privacy of Wallfix side enclosure can be combined with Aerolux system to optimise outdoor living areas visually.



## Dimension Ranges

Width dimension: Any value between 1800mm and 4000mm  
 Projection dimension: Adjustable according to louvre quantity

		WIDTH	
		1800	4000
NR. OF LOUVRES	6	1569	
	7	1764	
	8	1959	
	9	2154	
	10	2349	
	11	2544	
	12	2739	
	13	2934	
	14	3129	
	15	3324	
	16	3519	
	17	3714	
	18	3909	
	19	4104	
	20	4299	
	21	4494	
	22	4689	
	23	4884	
	24	5079	
	25	5274	
	26	5469	
	27	5664	
	28	5859	
	29	6054	

Single Module  
 W: 1800 mm < 4000 mm  
 P: 1569 mm < 6054 mm

Multiple Modules Joining Type 1  
 W: 3600 mm < 8000 mm  
 P: 1569 mm < 6054 mm

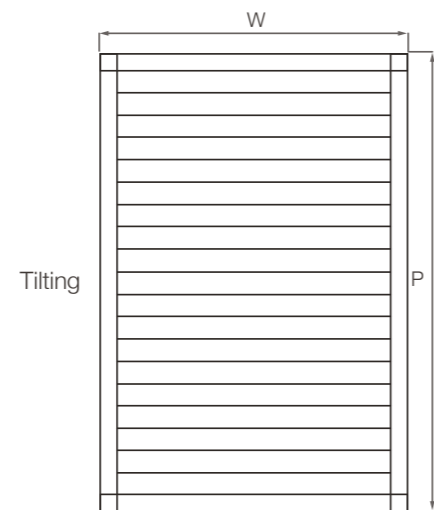
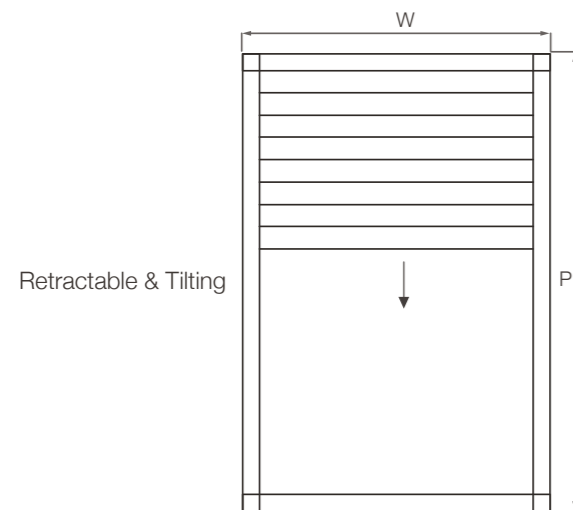
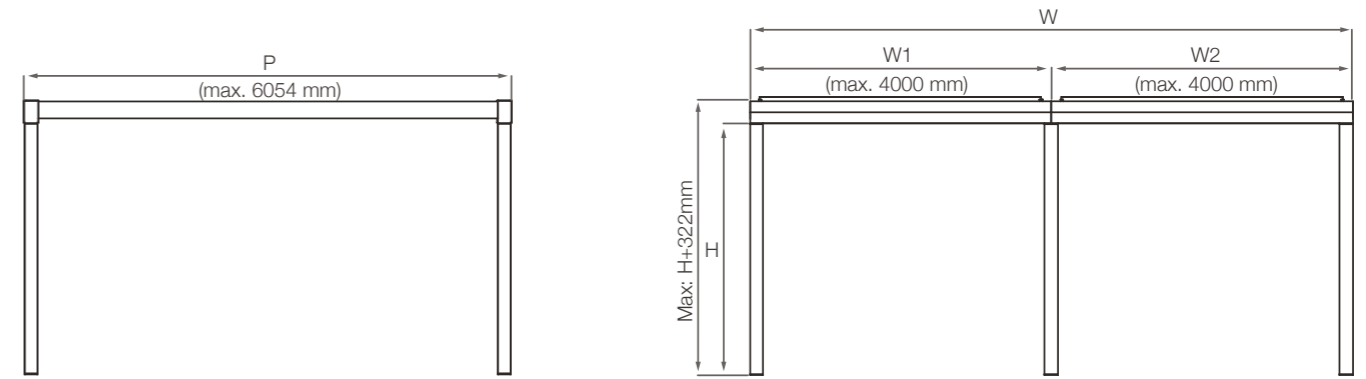
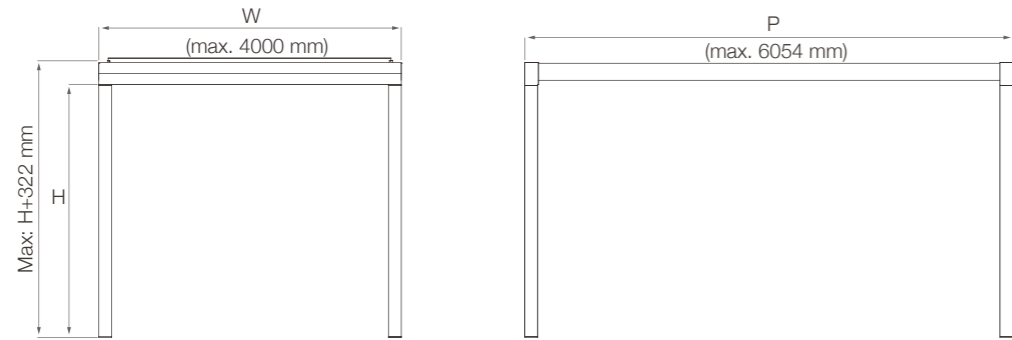

Retractable & Tilting

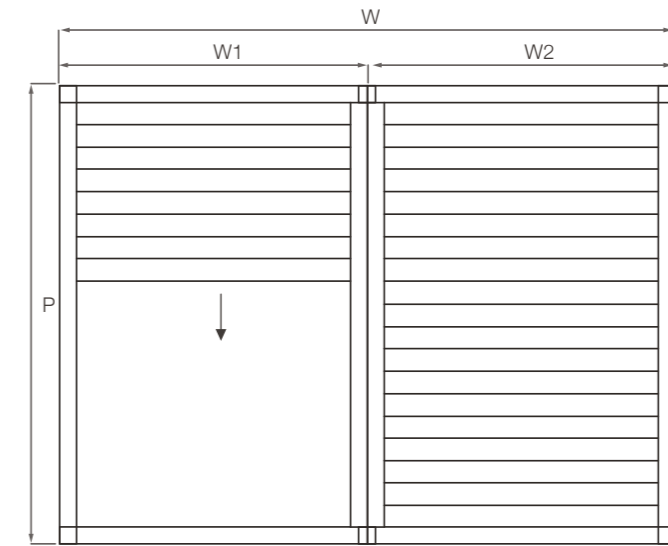

Tilting

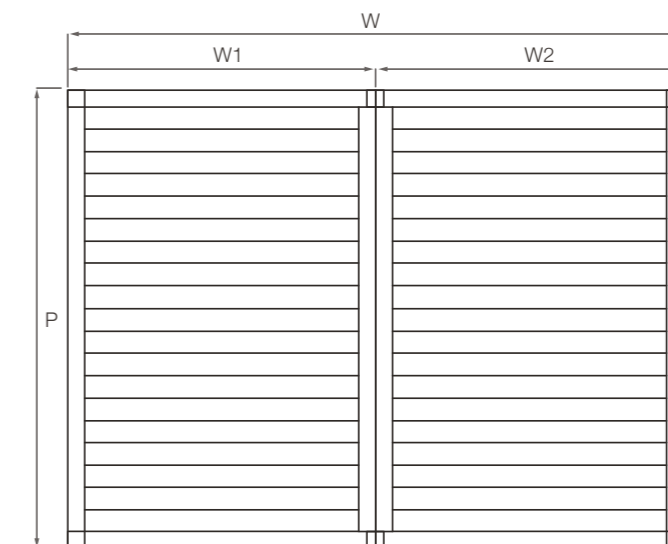

Multiple Modules Joining Type 2  
 W: 1800 mm < 4000 mm  
 P: 3138 mm < 12108 mm

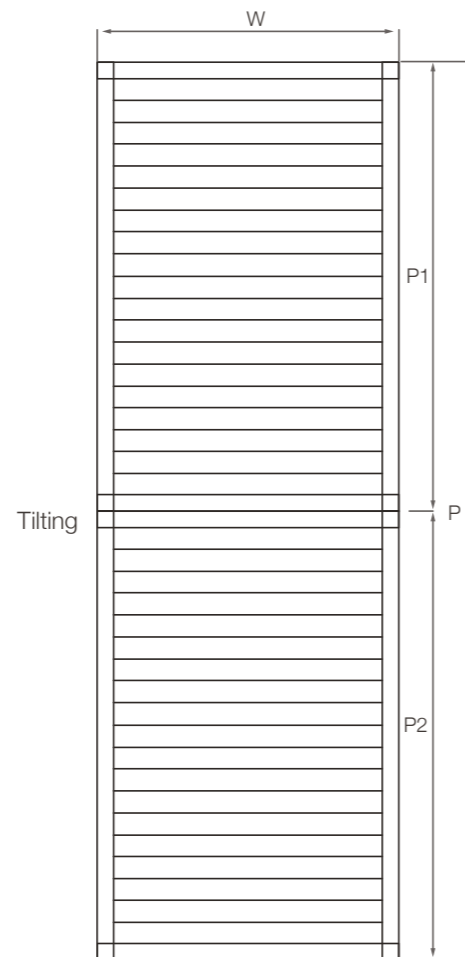
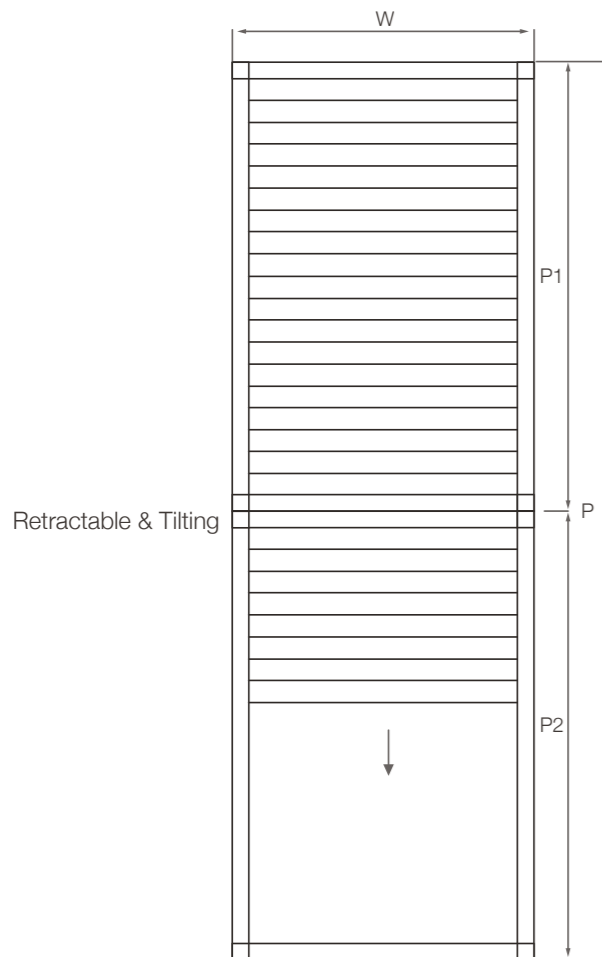
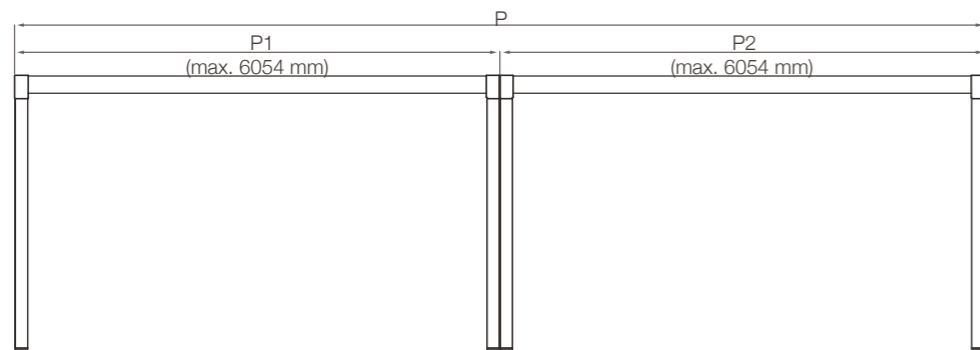
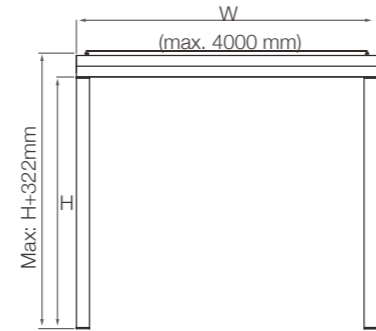

## Order Form

Company Name:  
 Order Reference:

Order Date:

### OPERATION

- Retractable & Tilting
- Tilting

### INSTALLATION TYPES

- Self Standing
- Wall Mounting
  - Louvres Parallel to Wall
  - Louvres Vertical to Wall

QUANTITY: ..... pc

If modules are multiple and each module is in different width or projection, please provide details (single module max. dimension is 4000x6054mm)

### DIMENSIONS

W - Total Width..... mm  
 P - Projection ..... mm  
 H - Post Height..... mm  
 Total Number of Posts Required ..... pc

Type 1       Type 2  
 W1 ..... mm      P1 ..... mm  
 W2 ..... mm      P2 ..... mm  
 ....  
 ....

### POWDER-COAT COLORS

#### Structure

RAL colors	Exclusive colors	Texture colors	<input type="checkbox"/> Other ...
<input type="checkbox"/> 9016	<input type="checkbox"/> OGN35	<input type="checkbox"/> ST9010	<input type="checkbox"/> Other ...
<input type="checkbox"/> 1013	<input type="checkbox"/> OS561	<input type="checkbox"/> ST9001	
<input type="checkbox"/> 9006	<input type="checkbox"/> OY395	<input type="checkbox"/> ST1013	
<input type="checkbox"/> 7006	<input type="checkbox"/> OGN39	<input type="checkbox"/> ST7039	
<input type="checkbox"/> 7016	<input type="checkbox"/> ON617	<input type="checkbox"/> ST7016	
<input type="checkbox"/> 9005	<input type="checkbox"/> ON611	<input type="checkbox"/> ST8019	

#### Louvres

RAL colors	Exclusive colors	Texture colors	<input type="checkbox"/> Other ...
<input type="checkbox"/> 9016	<input type="checkbox"/> OGN35	<input type="checkbox"/> ST9010	<input type="checkbox"/> Other ...
<input type="checkbox"/> 1013	<input type="checkbox"/> OS561	<input type="checkbox"/> ST9001	
<input type="checkbox"/> 9006	<input type="checkbox"/> OY395	<input type="checkbox"/> ST1013	
<input type="checkbox"/> 7006	<input type="checkbox"/> OGN39	<input type="checkbox"/> ST7039	
<input type="checkbox"/> 7016	<input type="checkbox"/> ON617	<input type="checkbox"/> ST7016	
<input type="checkbox"/> 9005	<input type="checkbox"/> ON611	<input type="checkbox"/> ST8019	

### LED LIGHTS

- Led Stripe Dimmer Lighting
  - Cool White
  - Day Light
- RGB Led - Hidden Stripe Lighting

### SENSORS

- Rain Sensor
- Wind Sensor

### OPTIONALS

- Additional Post
- Insulation Foam
- Drainage Pipe

### COLUMN BASE OPTIONS

- Hidden (Standard)
- Flange
- Flange With Cover Cap

### FLANGE POSITIONS

- Type A
- Type B
- Type C

### DRAINAGE TYPES

- Type I
- Type II
- Type III
- Type IV

### PACKAGING

- Standard
- Wooden Crate  
Extra cost

ADDITIONAL NOTES & DRAWINGS ATTACHED



## Technical Details



Max. width for single module	4000 mm
Max. projection single module	6054 mm
Rafter profile dimension	228x260 mm
Post dimension	160x160 mm
Louvre dimension	180 mm
Louvre quantity in max. size	29 pcs
Louvre can be tilted up to	90°
Louvres parking area	23%
Automation	included
Control unit	included
Led Stripe Dimmer lighting	optional
RGB Led - Hidden Stripe lighting	optional
Insulation foam	optional
Edge cover profile	N/A
Drainage pipe	optional
Flange	optional
Rain Sensor	optional
Wind Sensor	optional

## Technical Specifications Aerolux

New Generation Outdoor Covering Solutions  
With Tilting And Retractable Bioclimatic Systems

### Description

Aerolux is a new generation of high-tech bioclimatic covering solution that is composed of a high grade structural aluminium frame and tilting & retractable aerofoil louvres.

### Dimensions

#### One module

Width 1800 mm < 4000 mm

Projection 1569 mm < 6054 mm

Column Height 3000 mm

- Blocked assembly for customized modules with a wide range of flexible combinations.

### Technical Characteristics

- Extruded aluminium frame, blades & gutters - clean edges.
- Electrostatic powder-coated frame.
- High-quality aluminum extrusion profiles (Aluminium Alloy 6063-T6).
- Concealed screws to offer clean finish.
- High grade stainless steel connection components.
- High strength timing belt for balanced movement inside rafters.
- Large span with 4000mm dimension.
- Remote control for operation of mechanism and lighting.
- Double-walled aerofoil louvres with superior strength and durability.
- Adjustable louvres for any position within the 90° range.
- Extended open sky when roof retracted (open sky up to %77).
- Dimmer option to adjust lux intensity.
- Antibacterial polyurethane foam insulation which can be integrated into the louvre to provide sound and heat insulation.
- Air and water insulation between joining axis of multiple applications is provided by patented storm channel profile.
- Applicability of guillotine, sliding / sliding frame / folding glass and zip systems.



- Fully waterproof coverage when louvres are in fully closed position.
- Functional seal integration on louvre channel to prevent water leaking and provide extra insulation.
- The water is flowed down to the main gutters by special drainage channels along the louvres and drained through columns.
- Internal rainwater down-pipe for columns.
- Hidden direct drive double shaft motorbox with 56 NM torque Somfy® motor operates tilting and retracting motion. (2 pieces).
- Production in compliance with CE, ISO 9001, ISO 1400 and NVA standarts.
- In addition to standart RAL colors, Exclusive and Texture range aluminium colors can be offered as extended selection.
- Functional louvre lay out in parallel or vertical position to wall.

II | Profile Section Dimensions

- Rafter : 228 mm x 260 mm x 2,5 mm
- Gutter : 161 mm x 140 mm x 2,5 mm
- Column : 160 mm x 160 mm x 3 mm
- Louvre : 237 mm x 40 mm x 1,8 mm

III | Installation Methods

- Individual modules can be customised according to specified finish up to 4000mm width and 6000mm projection with flexible installation methods such as integration into existing frameworks, wall mounting and free standing for larger outdoor areas.
- System can be assembled as single or multiple modules.

IV | Columns

- Dimensions: 160 x 160 mm x 3 mm.
- Simple column assembly.
- The column cap profile can be pulled out simply and inner column cavity conceals the wiring cables of heater, speaker or automation to provide pure appearance.
- 3 different column base options: Hidden, Flange, Flange With Cover Cap.

V | Weather Resistance

Wind Resistance

- Wind rating up to Beaufort number 10 (up to 102km/h).

Water Drainage

- The four sided gutter for completely ensured waterproofness.
- Water drainage with an intensity of 155 L/h/sqm that last up to 2 minutes maximum.
- Optional PVC pipe (Ø70) integration inside columns.
- Customised drain points flexibility.

Snow load

See dimension based snow chart below;

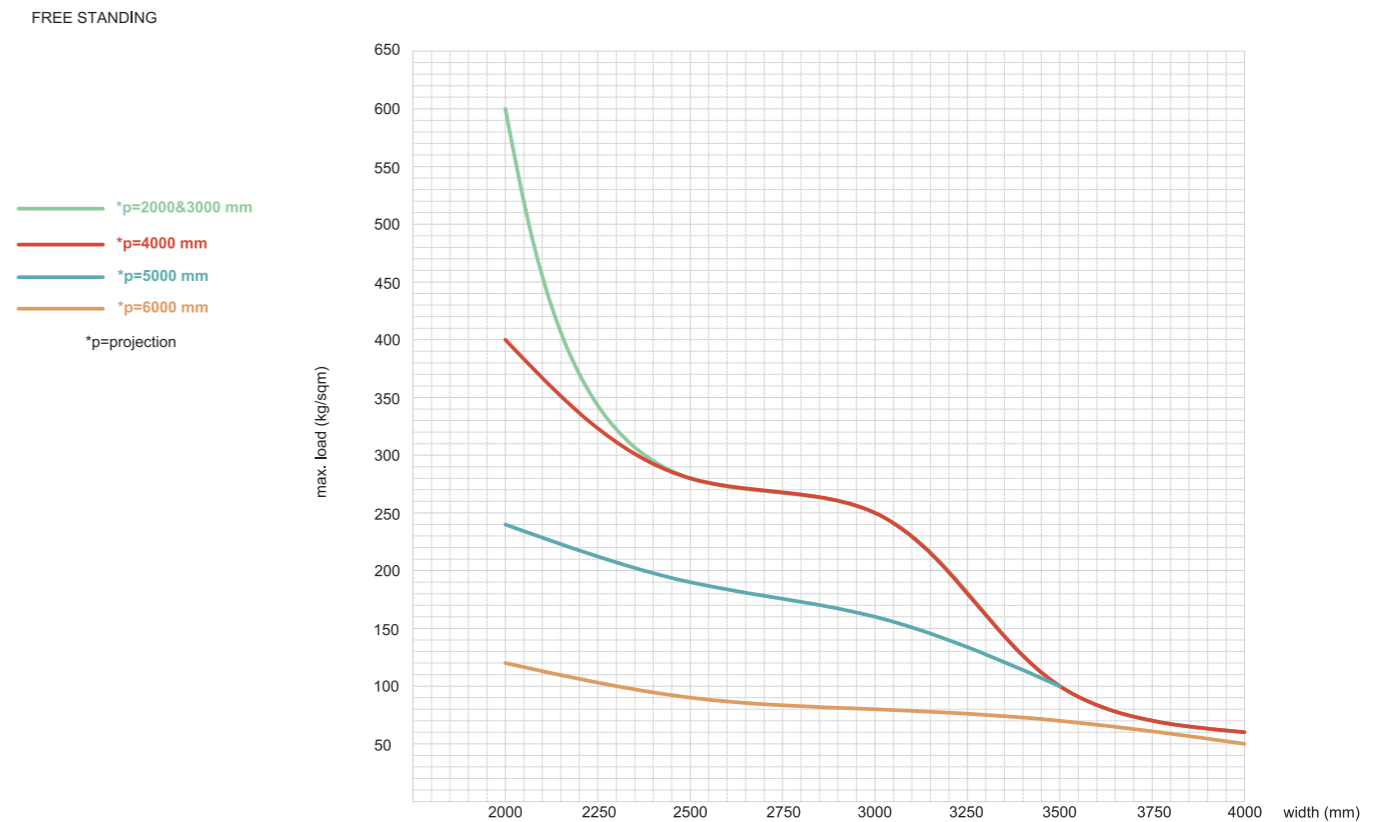

VI | Tests

Our systems are subjected to variety of tests in order to check their resistance under every type of circumstances.

Tests done following the requirements of International Standards involving parameters such as wind resistance and rainfall or snowfall demonstrate the excellent performance of our pergolas against the most adverse conditions.



Standard UNE-EN 13659:2004+A class 6 (approx. 102 km/h) tested up to 102 km/h without breaking within test bench parameters.



≤600 kg/m<sup>2</sup> (including its own weight) Standard EN-1999 EUROCODE 9 aluminium structures project.

\*Values will be decreased based width and projection dimensions.



Standard UNE-EN 12056-3, (0,04 l/s max.) constant heavy rain aprox. 155 l.m<sup>2</sup>/h (structures + slats).

VII | Additional Equipments

- Heater, speaker, air conditioner or other automations can be integrated.
- Wind and rain sensors can be adapted.

VIII | Lighting

Integrated RGB-Led Hidden Stripe and Led Stripe Dimmer Lighting on sides within the structure.

- Led Stripe Dimmer Lighting

Cool White, 60 LEDs/m I +5100-6500K I 1130 lumens/m

Day Light, 120 LEDs/m I +2800-3500K I 1094 lumens/m

- RGB Led-Hidden Stripe Lighting

60 LEDs/m

IX | Sensors

Wind and rain sensors can be adapted for an optimum level of comfort. These smart sensors are designed to respond fully automatic based on weather conditions in a specific situation. It functions as a protection against unexpectable weather conditions.

Sensors will activate an automated system that close/retract the roof and protect the furniture & underneath of covered area even if you are not able to control the system.

**Wind sensor**

Wind sensor monitors the gust of wind then retract your outdoor product to protect it against unexpected strong winds and offers constant protection.

The wind speed value required to do this is set directly at the sensor. If the wind picks up significantly wind sensor will close the roof depending on a pre-set wind speed. Thanks to ease of installation and minimal cabling it can be setup simply.

**Rain sensor**

Rain sensor will automatically detect the rain and close your roof to prevent raindrops falling through open roof systems even if you are not able to control the system.

If rain is detected the pergola will be closed and the remote control will be needed to open it back.

X | Closures

Systems can be completely enclosed with Sapphire automatic vertical glass system, Swind windbreaker system, Violet, Framee, Slidia or motorised Vertex zip for further protection from the elements.

**Sapphire**

Sapphire is an automatic vertical guillotine glass system enriched with patented worm shaft technology.

- Systems can incorporate framed tempered 8 mm and 10 mm single or 4mm+12mm+4mm / 5mm+10mm+5mm double insulated glazing.
- Optional 2 or 3 panels configurations are available up to 4 meters width and 3 meters height or 3 meters width and 3,5 meters height.
- Electrostatic powder-coated frame.
- Operation is motorised.
- Upwards or downwards parking position options.
- Fixed panels can be used as balustrades.
- The position of movable panels can be adjusted according to desired height.
- Thanks to strengthened counterweight movement mechanism motor provides balanced&silent up/down operation.
- Fully hidden motor drive.
- Switch, remote or smart home control availability.
- Fine frames with thermal and sound insulated rubber seals.
- Wide open view with up to 4 meters width vertical glass panels.

**Cycle**

Cycle is an automatic vertical guillotine glass system with strengthened chain mechanism.

- Systems can incorporate framed tempered 5mm+11mm+5mm double insulated glazing.
- Optional 2 or 3 panels configurations are available up to 4 meters width and 3 meters height or 3 meters width and 3,5 meters height.
- Electrostatic powder-coated frame.



- Motorised operation with switch, remote or smart home control availability.
- Upwards or downwards parking position options.
- Balustrade usage ability with the handrail design that covers the glass panels.
- The position of movable panels can be adjusted according to desired height.
- Thanks to strengthened counterweight movement mechanism motor provides balanced&silent up/down operation.
- Fully hidden motor drive.
- Protected usage with safety sensor.
- Fine frames with thermal and sound insulated rubber seals.
- Easy assembly & disassembly with compact guide profile consisting of four parts.
- Wide open view with up to 4 meters width vertical glass panels.

### Swind

Swind is an automatic vertical up-down glass panel.

- Electrostatic powder-coated frame.
- Extruded aluminium fix panel frame.
- Concealed screws to offer clean finish.
- Horizontal counterweight for smooth motion.
- High strength belt mechanism for balanced movement.
- 10mm fixed and 8mm up-down automatic moveable tempered glass panels.
- Frameless moveable glass panel for unobstructed view.
- Led stripe dimmer lighting integrated side frame / invisible electrical cables.
- Remote control for operation of mechanism and lighting.
- Fast opening-closing cycle.
- Fully hidden compact direct drive motor system.
- Ease of installation with single or multiple modules.
- Portability with optional wheel integration.
- Availability of usage as balustrade in closed position.
- Transparent panels in standards besides Smoked, Green, Blue and Bronze color options.

### Violet

Violet glass balustrade system.

- Concealed screws to offer clean finish.
- Glass fixed pane is 8+1.52 pvb+8mm.
- Led stripe dimmer lighting integrated underneath the glass / invisible electrical cables.

- Remote control for operation of lighting.
- Ease of installation with single or multiple modules.
- Availability of usage as Hand Rail (Optional).
- Compact & Easy Assembly.
- Transparent panels in standards besides Smoked, Green, Blue and Bronze color options.

### Framee

Framee, sliding glass system with fine-framed double glazed panels.

- Double insulated glass (6+12+6mm).
- Transparent sliding glass panels in standard besides of Blue, Green, Smoked and Bronze glass color options.
- Electrostatic powder-coated frame.
- Handle with Click Lock on first panel and Handle with Hidden Lock on the last panel on internal side of sliding panels for security measures.
- Combination availability with Vertex Zip System for sun protection.
- Available with 2,3 or 4 rails up to maximum 8 panels combined with side or central openings.
- Natural, stainless steel and black anodyse color options.

### Slidia

Slidia is a sliding glass system with individual parallel glass panels.

- Electrostatic powder-coated frame.
- Features slim aluminum glass profiles.
- Individual panels can be moved horizontally with single or double slide options.
- Bottom wheel carriages with double rollers ensure optimum and smooth running even with wide glass panels.
- Successive panels can be moved by the grap mechanism.
- Height adjustable wheel carriages up to 5mm.
- Sloped rail design for efficient drainage.
- Anodised bottom rail for easy and smooth movement.
- Rain and wind resistance by double sided transparent gaskets (standard), transparent gaskets with brush or aluminum slats with brush.
- Brush and rubber cord for high frame insulation.
- Anti-slip rubber ensures safety passage and also offers ease of rail surface cleaning.
- Transparent sliding glass panels in standard besides of Blue, Green, Smoked and Bronze glass color options.
- Internal or external locking of the sliding panels by optional key lock for security measures.
- Flush Circle and Push & Pull Bar handle types and Allen&Key lock.
- Combination availability with Vertex Zip System for sun protection.
- Available with 3 or 5 rails up to maximum 10 panels, combined with side or central openings.



**Vertex Zip System**

Vertex is a motorised external blind system.

- It provides comfortable shade and protects against the UV rays.
- The system includes motorised aluminium structure.
- Each screen has a pair of identical side channels.
- Entirely powder-coated with stainless steel components.
- Maximum protection against solar radiation and penetration of heat while preserving the optimal level of natural light in the interior and contact with environment.
- The production technology of fabrics ensures a high resistance to external influences such as wind or changes in temperature and humidity.

**Wallfix**

Wallfix is an aluminum louvered fixed wall system.

- Electrostatic powder-coated frame.
- High-quality aluminum extrusion profiles (Aluminium Alloy 6063-T6).
- Compact & Easy Assembly with click louvre connection.
- Clean finishes with hidden joining details.
- Extruded aluminium fine line fixing frame.
- Concealed screws to offer clean finish.
- Large span with 6000mm dimension.
- Sound and heat insulation with double layered louvre (panel) design.
- Maximum safety with block assembly.

**Doors**

**Glass door**

- Frameless hinged and frameless hydraulic glass doors are available.
- Single tempered glass (10mm).
- Available with single panel and double panels (each panel in maximum 1000mm).
- Flush Circle and Push & Pull Bar handle types and Allen&Key lock.
- Transparent panels in standards besides Smoked, Green, Blue and Bronze color options.
- Handle position height can be adjusted as desired (Standard height value is 110cm).
- Allen&Key lock for security.

**Framed glass door**

- Hinged and hydraulic framed glass doors are available.
- Electrostatic powder-coated frame.
- Available with double insulated single panel and double panels (each panel in maximum 1000mm).
- Double insulated glass (4+11+4mm).
- Transparent panels in standards besides Smoked, Green, Blue and Bronze color options.
- Handle position height can be adjusted as desired (Standard height value is 110cm).
- Internal or external locking of the sliding panels by optional key lock for security measures.
- Push & Pull Bar handle types.
- Pull Handle/ Lock.

**Photocell Door**

- Aluminum framed automatic glass door.
- Electronic lock.
- Possibility of manuel usage in emergency situations.
- Electrostatic powder-coated frame.
- Available in Laminated glass (4+4mm).
- Single panel and double panel options (each panel in maximum 1000mm).
- Fast opening-closing cycle and insulation materials for preserving heat balance between indoor and outdoor.
- Transparent panels in standards besides Smoked, Green, Blue and Bronze color options.
- One side button or double side button and double sided transition control types.

**XI | Structure Color Options / Finishes**

- The products are available with a wide range of colour options in standard or architectural textured coatings.
- In addition to standard RAL colors, Exclusive and Texture range aluminium colors can be offered.
- QualiMarine and Qualanod finishes are also available beside of Qualicoat finishes.

**XII | Warranty**

	Aerolux	Sapphire	Cycle	Swind	Violet	Framee	Slidia	Vertex	Wallfix
Structure& Coating	5 years	5 years	5 years	5 years	5 years	5 years	5 years	5 years	5 years
Mechanics	2 years	2 years	2 years	2 years	N/A	2 years	2 years	2 years	N/A
Motor&Control Units	2 years	2 years	2 years	2 years	2 years	N/A	N/A	2 years	N/A
Lighting& Control Units	2 years	N/A	N/A	2 years	2 years	N/A	N/A	N/A	N/A

\*End user and installation defects are not covered.

# ENQUIRIES AUSTRALIA WIDE

Phone: 1300 856 499

Email: sales@sbdau.com.au

## HEAD OFFICE

Structures By Design Australia

16/15 Earsdon St

Yarraville, VIC 3013

Phone: 1300 856 499

AEROLUX



### Overview

#### Operations

Retractable & Tilting



Tilting

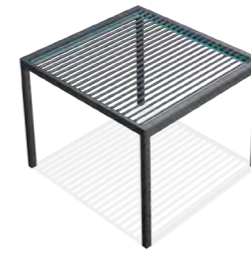

### Lighting Options

Led Stripe Dimmer Lighting

Cool White



Day Light



RGB Led-Hidden Stripe Lighting

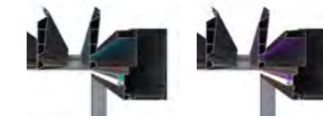

### Optional

Insulation Foam



### Sensors

Rain Sensor



Wind Sensor



### Installation Types

Self Standing Single Module



Self Standing Multiple Modules



Wall Mounting Single Module



Wall Mounting Multiple Modules



### Closures

Sapphire & Cycle



Swind



Violet



Framee



Slidia



Vertex



Wallfix

